

CAVIUS

THE WORLDS
SMALLEST
SMOKE
ALARM



DANISH
DESIGN



5 YEAR
BATTERY

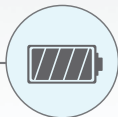

100%
TESTED

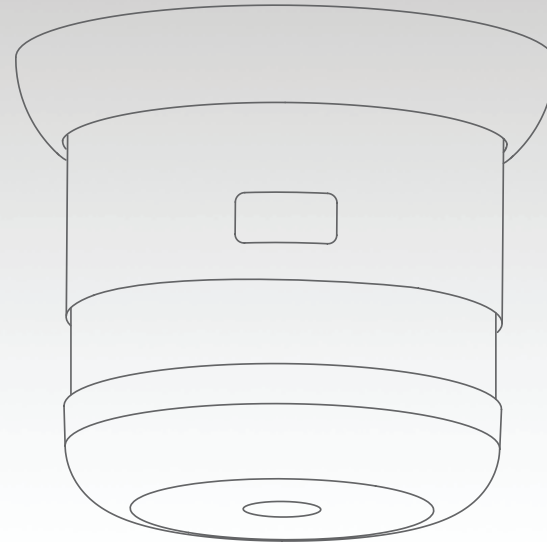

5 YEAR
SMOKE
ALARM

PRODUCT NAME: CAVIUS SMOKE ALARM, 5 YEAR 40MM

PRODUCT NUMBER: 2001





PRODUCT NAME: CAVIUS SMOKE ALARM, 5 YEAR 40MM

PRODUCT NUMBER: 2001

PRODUCT DATA:

DEVICE TYPE:

Optical smoke alarm device.

USAGE:

Designed for installation in private homes, camping trailers, mobile homes and caravans.

FUNCTION:

The alarm makes an optical reading every 8 seconds. At unusual readings (going into alarm stage), the readings are taken every 2 seconds.

INSTALLATION POSITION:

Wall & ceiling. Set of 2 x screws and 2 x plugs included.

PRODUCT DIMENSIONS:

D: 40 mm. x H: 41 mm.

PRODUCT WEIGHT:

Base alarm weight (excluding battery screws, plugs and mounting ring): 31g.

OPERATION AC/DC:

DC

BATTERY TYPE:

3V CR2 Lithium battery, 850mAh (replaceable)

BATTERY LIFE:

Minimum 5 year life in normal operating condition. (Based on a weekly testing).

POWER CONSUMPTION:

Battery consumption is 93mAhour in the non alarm condition.

LOW BATTERY INDICATION:

A short acoustic "beep" will sound and LED flash every 48 seconds when the voltage is below 2.85V. In this stage it will continue for minimum 30 days, and can drive the alarm for 4 minutes.

NORMAL OPERATION:

LED flashes every 48 second for normal operation.

SOUND:

Audible indicator min. 85 dB @ 3 meter.

SOUND PATTERN:

Fire alarm condition is indicated by a series of three successive tones.

VISIBLE INDICATOR:

A red LED is used to indicate the following conditions:

- fire alarm condition is indicated by a flash every 0.5 seconds
- smoke sense speed up is indicated by a flash every 2 seconds when the smoke level is at the alarm threshold
- normal operation is indicated by a flash every 48 seconds

PUSH BUTTON:

The smoke detector includes a push button switch. This button has the following functions:

- hush – during an alarm condition this immediately silences the alarm when pressed. When the button is released, the alarm remains silenced for 10 minutes
- test – when not in alarm the sounder can be activated to provide a sensor OK test function. While the button is pressed, the audible and visible indicators are activated if the sensor is OK

DETECTION TIMING:

The smoke detector is reading every 8 seconds, every 2 seconds at unusual readings (alarm stage).

ISOTOPE ACTIVITY:

Absence of radioactive substances.

WARRANTY:

10 year

APPROVALS:

EN 14604:2005
EN60065
NF292
RoHS
REACH

CE TESTING INSTITUTE:

CNPP



PRODUCT NAME: CAVIUS SMOKE ALARM, 5 YEAR 40MM

PRODUCT NUMBER: 2001

PRODUCT DATA:

NOTIFIED BODY:

CNPP Certification

ADDITIONAL TESTING AND APPROVALS:

DVN (Dansk Varedeklarations Nævn)

NOTIFIED BODY NUMBER:

1116

AWARDS:



reddot design award
winner

ASSOCIATIONS AND COMMITTEES:

CAVIUS is member of the NF292 committee.

CAVIUS is member of GIFSID, manufacturers' association of domestic fire safety equipment.

OPERATING TEMPERATURE:

+4°C to +38°C (tested from 0 degrees to 55 degrees)

OPERATING HUMIDITY:

Up to 90% RH non-condensing

STORAGE TEMPERATURE:

-20°C to +60°C

STORAGE HUMIDITY:

Up to 93% RH non-condensing

QUALITY ASSURANCE:

SOUND LEVEL:

100% tested in special designed sound chamber.

SENSITIVITY:

100% tested in special designed test tunnel made by world leader AWT (UK).

POWER CONSUMPTION:

100% tested

BATTERY VOLTAGE AND INTERNAL RESISTANCE:

100% tested

ALARM FUNCTION:

100% tested

VISUAL APPEARANCE:

100% tested

PACKING CONTENT:

100% tested

CONTACT

www.cavius.com

MANUFACTURER

Manufacturer: CAVIUS Aps, DK8260

CAVIUS



THE WORLDS
S M A L L E S T
SMOKE
A L A R M

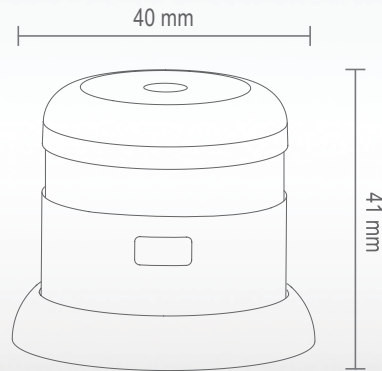

PRODUCT NAME: CAVIUS SMOKE ALARM, 5 YEAR 40MM

PRODUCT NUMBER: 2001

DISTRIBUTOR:

